



## Durgo Verkstads AB

Box 3021  
S 16903  
Solna  
Sweden  
Tel: 00 46 8 730 5280 Fax: 00 46 8 735 6955  
e-mail: sales@durgo.se  
website: www.durgo.se

**Agrément  
Certificate  
No 06/4325**

Designated by Government  
to issue  
European Technical  
Approvals

## DURGO AIR ADMITTANCE VALVES

Vanne d'adduction d'air  
Luft Zulassung Ventil

## Product



- THIS CERTIFICATE REPLACES CERTIFICATE No 97/3427 AND RELATES TO 32 mm, 56 mm, 82 mm, 110 mm AND 125 mm DURGO AIR ADMITTANCE VALVES.
- The valves are for use in above-ground drainage systems designed in accordance with this Certificate and have met the performance requirement of BS EN 12380 : 2002.
- The valves provide a means of ventilation to the drainage system to prevent the loss of water seals in traps and consequent release of foul air into the building.

## Regulations

### 1 The Building Regulations 2000 (as amended) (England and Wales)



The Secretary of State has agreed with the British Board of Agrément the requirements of the Building Regulations to which air admittance valves can contribute in achieving compliance. In the opinion of the BBA, Durgo Air Admittance Valves, used in accordance with the provisions of this Certificate, will contribute to meeting the relevant requirements.

Requirement: H1

Foul water drainage

Comment:

Durgo valves will:

- provide adequate ventilation to prevent the loss of water seals in trapped appliances. See sections 7.1 to 7.7, 8.1 to 8.9, 9.1 and 9.2 of this Certificate
- prevent foul air from entering the building. See section 9.1 of this Certificate
- enable access to the sanitary pipe work for clearing blockages. See section 8.1 of this Certificate
- contribute to the ventilation of underground drains. See sections 8.2 and 8.3 of this Certificate.

Requirement: Regulation 7

Materials and workmanship

Comment:

The products are acceptable. See section 11 of this Certificate.

continued

# Electronic Copy

continued

- *The drainage systems and the installation and use of the valves must be in accordance with the conditions set out in the Design Data and Installation parts of this Certificate.*

## 2 The Building (Scotland) Regulations 2004



In the opinion of the BBA, Durgo Air Admittance Valves, if used in accordance with this Certificate, will satisfy or contribute to satisfying the various Regulations and related Mandatory Standards as listed below.

Regulation:	8	Fitness and durability of materials and workmanship
Regulation:	8(1)	Fitness and durability of materials and workmanship
Comment:		The product can contribute to a construction satisfying this Regulation. See section 11 and the <i>Installation</i> part of this Certificate.
Regulation:	9	Building standards — construction
Standard:	3.7(b)(c)	Wastewater drainage
Comment:		Sanitary pipe work incorporating the product can satisfy the requirements of this Standard with reference to clauses 3.7.1 <sup>(1)</sup> and 3.7.7 <sup>(1)</sup> . See sections 7.1 to 7.7, 8.1 to 8.9, 9.1 and 9.2 of this Certificate.
		(1) Technical Handbook (Domestic).

## 3 The Building Regulations (Northern Ireland) 2000



In the opinion of the BBA, Durgo Air Admittance Valves, if used in accordance with the provisions of this Certificate, will satisfy or contribute to satisfying the various Building Regulations as listed below.

Regulation:	B2	Fitness of materials and workmanship
Comment:		The products are acceptable. See section 11 of this Certificate.
Regulation:	N2	Drainage systems
Comment:		The valves provide adequate ventilation to prevent the destruction of the water seals in traps. See sections 7.1 to 7.7, 8.1 to 8.9, 9.1 and 9.2 of this Certificate.

## 4 Construction (Design and Management) Regulations 1994 (as amended) Construction (Design and Management) Regulations (Northern Ireland) 1995 (as amended)

In the opinion of the BBA there is no information in this Certificate which relates to the obligations of the client, planning supervisor, designer and contractors under these Regulations.

## Technical Specification

### 5 Description

5.1 Durgo Air Admittance Valves (see Figure 1) comprise an injection-moulded, two-part acrylonitrile butadiene styrene (ABS) body, snap-fitted and bonded together and incorporating a seating for sealing purposes. Two diametrically opposed holes in the lower moulding allow condensation to return to the discharge stack. The valve incorporates a sliding ABS disc and EPDM (ethylene propylene diene monomer) seal bought in to Durgo Verkstads AB's specification. In addition the 32 mm valve incorporates a stainless steel spring.

5.2 The range of components are detailed in Table 1. The valves each incorporate a spigot for insertion into ring seal sockets or ABS and PVC-U solvent weld sockets.

5.3 The valves incorporate spigots with diameters that are in accordance with the Standards for waste pipe, including: BS EN 1329-1 : 2000, BS EN 1451-1 : 2000, BS EN 1455-1 : 2000, BS EN 1519-1 : 2000, BS EN 1565-1 : 2000, BS 5255 : 1989 and BS 4514 : 2001.

5.4 An expanded polystyrene insulating cover is supplied to prevent condensation forming within the

valve under cold conditions. A label on the insulating cover cautions an installer not to remove it.

Table 1 Product range

Valve size (nominal diameter of spigot) (mm)	Product code	BS EN 12380 designation <sup>(1)</sup>	Use
32	152574	A1	see section 7.2
56	BA 5074	A1	see section 7.3
82	BA 7574	A1	see sections 7.4 and 7.5
110	BA 9074	B1	see sections 7.4 and 7.5
125	BA 12588	B1	see section 7.6

(1) A1 = permitted to be used below flood level in locations where the temperature is in the range of -20°C to 60°C.  
B1 = are rated at the same temperature but only for use above the flood level of the appliance served.

5.5 Continuous quality control is exercised during manufacture and assembly, including visual checks, checks on dimensional accuracy and airtightness. The raw materials and bought-in goods are subject to quality controls.

### 6 Delivery and site handling

Valves, complete with an insulating cover and installation instructions, are supplied in cardboard boxes and polyethylene bags, to limit the risk of contamination or damage. They must be stored upright in their boxes until required for use.

Figure 1 Durgo Air Admittance Valve

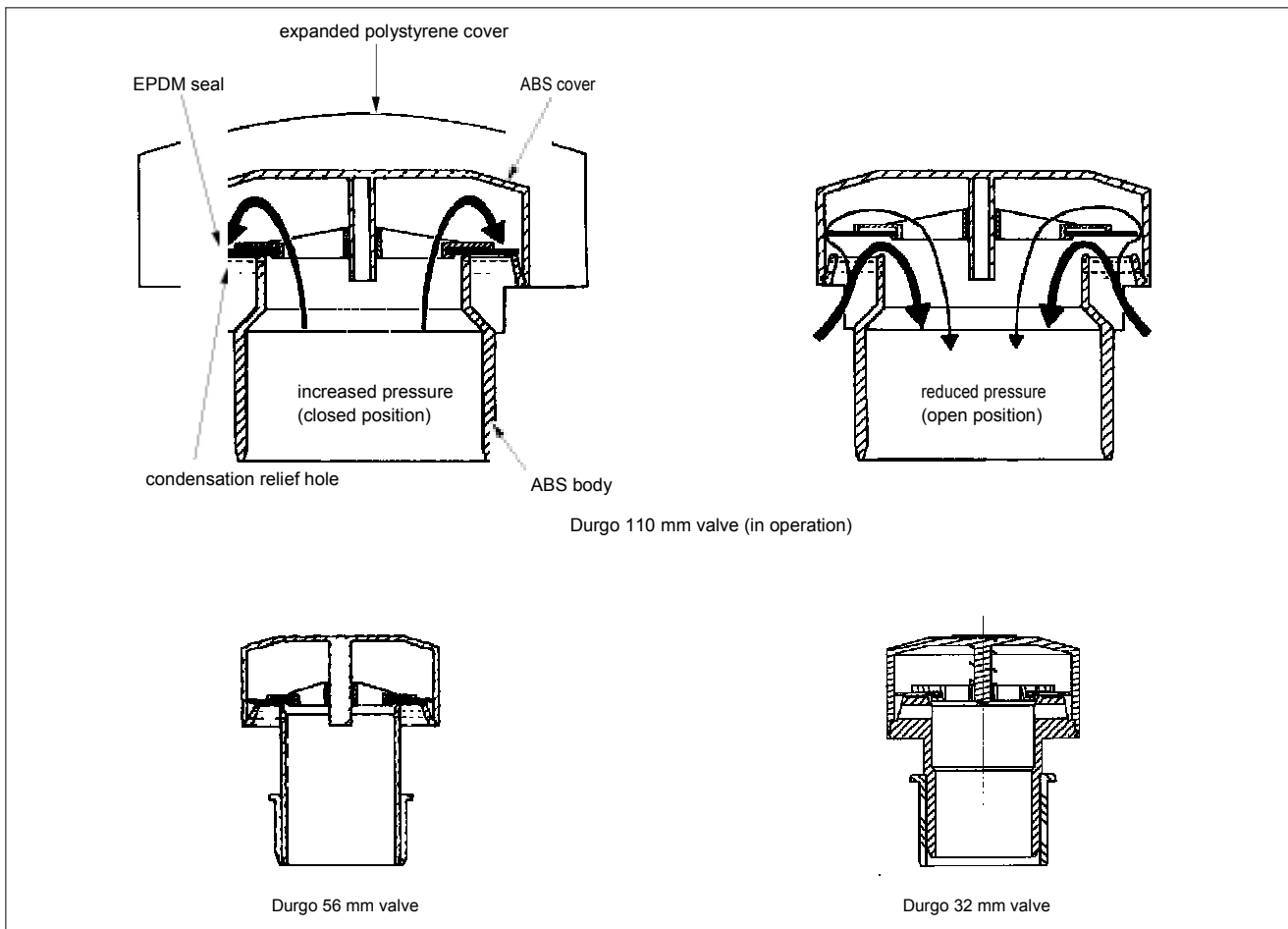

## Design Data

### 7 General



7.1 When Durgo Air Admittance Valves are used in above-ground drainage systems designed in accordance with BS 12056-1 : 2000 and BS 12056-2 : 2000 the valves will:

- admit air under conditions of reduced pressure in the discharge pipes and prevent water seals in traps from being drawn or evacuated
- prevent the release of foul air from the drainage system, and
- contribute to the ventilation of the main drain to which the discharge stack incorporating the valve is connected.

7.2 The 32 mm valve is for connection to waste pipes to prevent water loss from trap seals by self and induced siphonage arising from water flow in small diameter branch discharge pipes.

7.3 The 56 mm valve is for use on branch discharge pipes.

7.4 The 82 mm and 110 mm valves are for use on discharge stacks serving up to 10 storeys (see Figures 2 and 3).

7.5 The 110 mm valve may be used as a substitute for the 82 mm valve where the 110 mm spigot diameter makes it more convenient to install.

7.6 The 125 mm valve is for use on discharge stacks serving up to 12 storeys (see Figure 2). It may be used also as a substitute for the 110 mm valve where the 140 mm spigot diameter makes it more convenient to install.

7.7 The valves are for use in association with each other or separately.

### 8 Drainage system design



8.1 Drainage systems designed in accordance with BS EN 12056-1 : 2000 and BS EN 12056-2 : 2000 should be based on the airflow data given in Table 2. Typical installation details in accordance with BS EN 12056-1 : 2000 are given in Figures 2, 3 and 5. A technical advisory service is provided by Mr Rolf Payne, 67 Foxholes Hill, Exmouth, Devon EX8 2DH.

Table 2 Airflow performance<sup>(1)</sup>

Nominal size of pipe (mm)	Flow rate (litres per sec)
32, 36	7.4
56	16.9
82	37.1
110	44.3
125	83.3

(1) These results are based on tests carried out by the BRE in accordance with BS EN 12380 : 2002.



Figure 4 Drain ventilation provisions

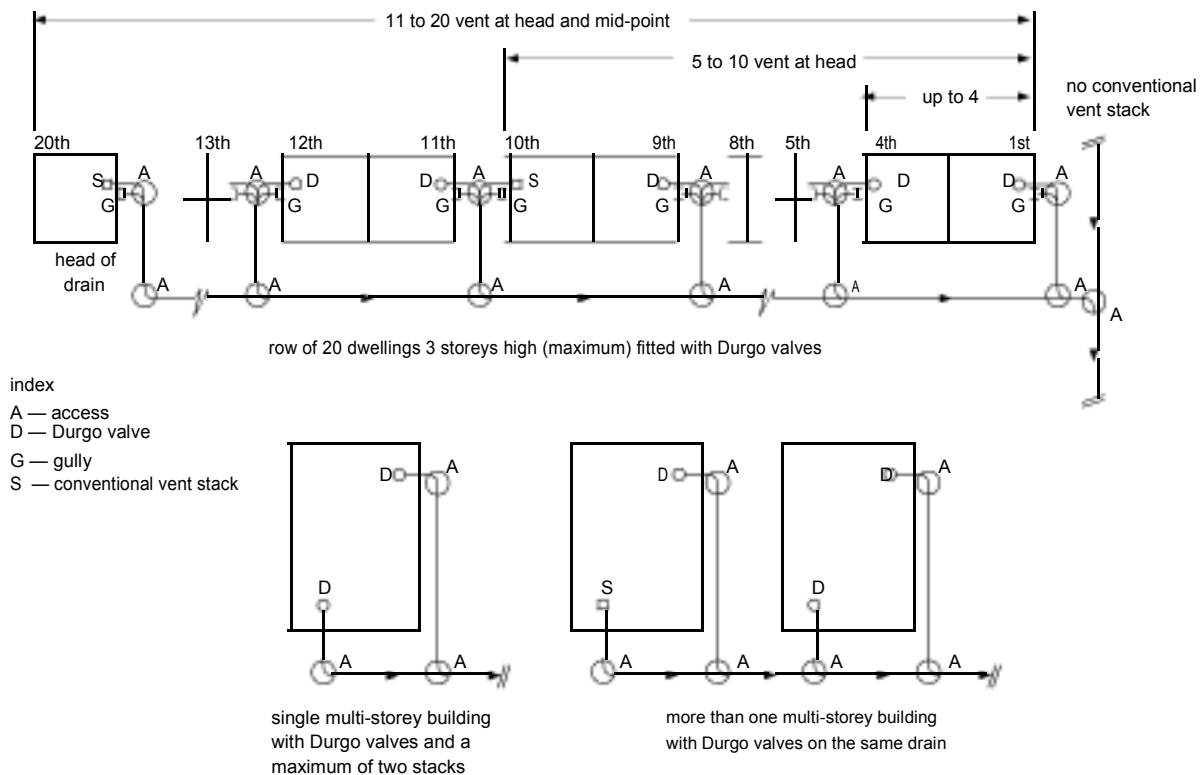

Notes: Access arrangements shown are indicative only and may be varied to suit particular system layouts.  
 The underground drain must be designed in accordance with BS EN 752-1 : 1996, BS EN 752-2 : 1997, BS EN 753-2 : 1997 and BS EN 752-4 : 1998.  
 If the branch drain is fitted with an intercepting trap before the connection to the main drain/sewer then a conventional open-topped ventilation discharge stack must be provided at the nearest point upstream of the intercepting trap.

8.2 To contribute to the ventilation of the underground drain and to minimise the effects of excessive back pressures when a drain blockage occurs, the branch or main drain serving a stack or stacks fitted with Durgo valves may require venting at a point upstream of the stack connection. For guidance the following should be noted (see Figure 4):

- for up to and including four dwellings, one, two, or three storeys in height, additional drain venting is not required. Where a drain serves more than four such dwellings equipped with the valve, the drain should be vented according to the following rule, either by a conventional open-topped ventilating stack or discharge stack:
  - 5 to 10 such dwellings — conventional ventilation to be provided at the head of the system
  - 11 to 20 such dwellings — conventional ventilation to be provided at the mid-point and at the head of the system.
- for multi-storey domestic dwellings (other than those referred to above) and non-domestic buildings, conventional drain venting should be provided if more than one such building, each equipped with the valves, is connected to a common drain which itself is not vented by means of a ventilating stack or a discharge stack not fitted with a valve.

8.3 In installations other than those shown in Figure 4, stacks should not be fitted with the valves when the connecting drain is subject to periodic surcharging or is fitted with intercepting traps. An open-topped discharge stack or ventilating stack should be used in such cases.

8.4 The valve should be installed either within the building, preferably in a non-habitable space, such as a duct or roof, or externally when protected within a ventilated duct where there is no risk of freezing, and where it is easily accessible but not subject to interference, eg from vandals.

8.5 If the valve is to be installed in, or in close proximity to, a habitable space where noise of operation may cause a nuisance, then consideration must be given to the use of a suitable form of sound insulation.

8.6 The insulating cover should be used when there is a possibility of condensation forming and freezing within the valve body.

8.7 If self-siphonage may occur, a connection to the 32 mm valve is required within 300 mm of the trap (see Figure 5).

8.8 To prevent induced siphonage in a row of wash basins, a 32 mm or 56 mm Durgo valve should be fitted between the two wash-basins furthest from the discharge stack (see Figure 5).

8.9 Air admittance valves should not be used when the discharge stack provides the only ventilation to septic tanks or cesspools.

## 9 Effect on water seals



9.1 Under conditions of increased pressure in the drainage system, each valve will remain closed, thereby preventing the release of foul air into the building. In a correctly designed drainage system incorporating Durgo valves in accordance with the recommendations given in this Certificate, increases in pressure will not be sufficient to cause traps in WC's or other appliances to become unsealed.

9.2 Should a pressure increase occur such that it is sufficient to cause the loss of water seals, it is an indication that a drain blockage has occurred or that the system is being overloaded or otherwise misused.

## 10 Maintenance

10.1 The valves do not require maintenance. In the event of damage they can be replaced easily.

10.2 Valves fitted to ring seal sockets can be removed to allow access for removal of blockages.

## 11 Durability



Durgo valves are manufactured from conventional materials in drainage systems. Repeated opening and closing will not

adversely affect the sealing or operation of the valve. When used in the context of this Certificate the product will not be subject to significant deterioration and will have a life equivalent to that of the drainage system in which it is installed.

## Installation

### 12 Procedure

12.1 Installation of Durgo Air Admittance Valves must be carried out in accordance with the manufacturer's instructions. Joints are effected by conventional ring seal or solvent weld joint methods.

12.2 When valves are fitted to a ring seal socket, a suitable lubricant recommended by the Certificate holder should be applied to the valve spigot.

12.3 Solvent weld connections must be made using solvent cement to BS 6209 : 1982. This cement is suitable for solvent welding the valves to ABS and PVC-U fittings. Care must be taken in making solvent welded joints to prevent contact with the moving parts of the valve. Solvent welding must not be used for connection to polypropylene or polyethylene pipes and fittings.

12.4 The valves must be fitted in a vertical position above the pipe being ventilated.

Figure 5 Typical non-domestic (eg offices, factories, schools and other types of public buildings)

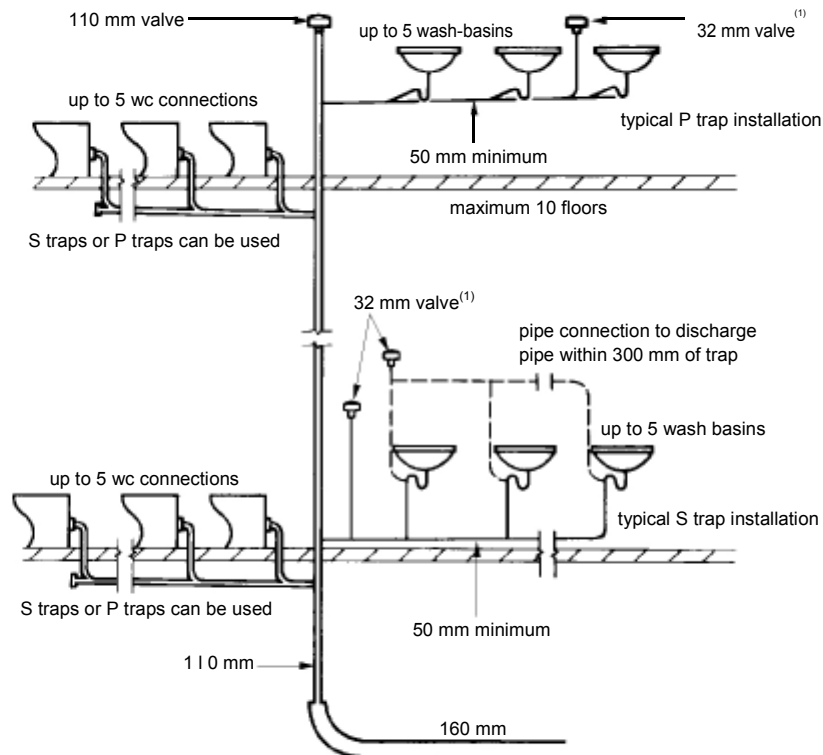

(1) The valve can be positioned below flood level (ie a level of which an appliance would overflow) in accordance with Table 1 of this Certificate.

Notes:

Valves to be fitted vertically.

If the valve is fitted inside a duct then the duct will require ventilation.

If access is required to the discharge stack then the valve must be fitted to a ring seal socket.

Branch discharge pipes to ranges of appliances must be designed in accordance with clause 7.2.3 of BS 12056-2 : 2000, where required branch pipe ventilation may be provided by the 56 mm Durgo valve.

12.5 The valves are installed in discharge and/or ventilating pipes and obviate the need to penetrate the roof covering. Care should be taken to avoid contamination of the sealing surfaces, as this may affect airtightness.

## Technical Investigations

The following is a summary of the technical investigations carried out on Durgo Air Admittance Valves.

### 13 Tests

13.1 As part of the assessment resulting in the issue of the previous Certificates Nos 82/977, 85/1557, 89/2285 and 97/3427 tests were carried out to determine:

- dimensional accuracy
- airtightness when tested to a pressure of 50 mm water gauge
- airtightness at low positive pressure
- reduced pressure required to open the valve
- effect of repeated operation.

13.2 Tests were carried out on the 32 mm and 125 mm valve to establish:

- airtightness when tested to a pressure of 40 mm and 200 mm water gauge
- effect of pressure cycling
- airtightness under normal operating conditions
- performance in use on a stack when tested in accordance with BS 5572 : 1994
- impact drop tested and correct functioning
- effect of repeated operation
- airtightness at low positive pressure
- reduced pressure required to open
- practicability of installation
- dimensional checks
- Shore hardness of diaphragm seals.

13.3 Tests were conducted to determine the performance in use for the conditions covered in the *Design Data* part of this Certificate.

13.4 Tests were carried out on the full range of valves in accordance with BS EN 12380 : 2002:

- drop test
- airtightness test at 30 Pa, 500 Pa and 10,000 Pa
- airtightness after endurance testing at 20°C and 60°C
- opening characteristics and airflow capacity
- effectiveness at temperatures below zero.

### 14 Investigations

14.1 The manufacturing process was examined including the methods adopted for quality control and details were obtained of the quality and composition of materials used.

14.2 A re-examination was made of the data on which the previous Certificates were based. The

conclusions drawn from the original data remain valid.

14.3 Data in relation to the following were examined:

- effect on trap seals when tested on five-storey test rigs
- self and induced siphonage
- stress relaxation
- creep durability.

14.4 Regular factory inspections have been carried out to ensure that quality is being maintained.

14.5 A user survey has been carried out to confirm performance in use.

14.6 An evaluation of the BRE and Valve Accessory and control, Sweden AB reports of tests to BS EN 12380 : 2002.

## Bibliography

BS 4514 : 2001 *Unplasticized PVC soil and ventilating pipes of 82.4 mm minimum mean, outside diameter and fittings and accessories of 82.4 mm and of other sizes — specification*

BS 5255 : 1989 *Specification for thermoplastics waste pipe and fittings*

BS 5572 : 1994 *Code of practice for sanitary pipework*

BS 6209 : 1982 *Specification for solvent cement for non-pressure thermoplastics pipe systems*

BS EN 752-1 : 1996 *Drain and sewer systems outside buildings — Generalities and definitions*

BS EN 752-2 : 1997 *Drain and sewer systems outside buildings — Performance requirements*

BS EN 752-3 : 1997 *Drain and sewer systems outside buildings — Planning*

BS EN 752-4 : 1998 *Drain and sewer systems outside buildings — Hydraulic design and environmental considerations*

BS EN 1329-1 : 2000 *Plastics piping systems for soil and waste discharge (low and high temperature) within the building structure — Unplasticized poly(vinyl chloride) (PVC-U)*

BS EN 1451-1 : 2000 *Plastics piping systems for soil and waste discharge (low and high temperature) within the building structure — Polypropylene (PP) — Specifications for pipes, fittings and the system*

BS EN 1455-1 : 2000 *Plastics piping systems for soil and waste (low and high temperature) within the building structure — Acrylonitrile-butadiene-styrene (ABS) — Specifications for pipes, fittings and the system*

BS EN 1519-1 : 2000 *Plastics piping systems for soil and waste discharge (low and high temperature) within the building structure. Polyethylene (PE) — Specifications for pipes, fittings and the system*

BS EN 1565-1 : 2000 *Plastics piping systems for soil and waste discharge (low and high temperature) within the building structure — Styrene copolymer blends (SAN + PVC) — Specifications for pipes, fittings and the system*

BS EN 12056-1 : 2000 *Gravity Drainage Systems inside Buildings — General and performance requirements*

BS EN 12056-2 : 2000 *Gravity Drainage Systems inside Buildings — Sanitary pipework, layout and calculation*

BS EN 12380 : 2002 *Air admittance valves for drainage systems — Requirements, test methods and evaluation of conformity*

15.3 This Certificate will remain valid for an unlimited period provided that the product and the manufacture and/or fabrication including all related and relevant processes thereof:

(a) are maintained at or above the levels which have been assessed and found to be satisfactory by the BBA;

(b) continue to be checked as and when deemed appropriate by the BBA under arrangements that it will determine; and

(c) are reviewed by the BBA as and when it considers appropriate.

15.4 In granting this Certificate, the BBA is not responsible for:

(a) the presence or absence of any patent, intellectual property or similar rights subsisting in the product or any other product;

(b) the right of the Certificate holder to market, supply, install or maintain the product; and

(c) the actual works in which the product is installed, used and maintained, including the nature, design, methods and workmanship of such works.

15.5 Any recommendations relating to the use or installation of this product which are contained or referred to in this Certificate are the minimum standards required to be met when the product is used. They do not purport in any way to restate the requirements of the Health & Safety at Work etc Act 1974, or of any other statutory, common law or other duty which may exist at the date of this Certificate or in the future; nor is conformity with such recommendations to be taken as satisfying the requirements of the 1974 Act or of any present or future statutory, common law or other duty of care. In granting this Certificate, the BBA does not accept responsibility to any person or body for any loss or damage, including personal injury, arising as a direct or indirect result of the installation and use of this product.

## Conditions of Certification

### 15 Conditions

15.1 This Certificate:

(a) relates only to the product that is named, described, installed, used and maintained as set out in this Certificate;

(b) is granted only to the company, firm or person identified on the front cover — no other company, firm or person may hold or claim any entitlement to this Certificate;

(c) is valid only within the UK;

(d) has to be read, considered and used as a whole document — it may be misleading and will be incomplete to be selective;

(e) is copyright of the BBA;

(f) is subject to English law.

15.2 References in this Certificate to any Act of Parliament, Regulation made thereunder, Directive or Regulation of the European Union, Statutory Instrument, Code of Practice, British Standard, manufacturers' instructions or similar publication, are references to such publication in the form in which it was current at the date of this Certificate.



In the opinion of the British Board of Agrément, Durgo Air Admittance Valves are fit for their intended use provided they are installed, used and maintained as set out in this Certificate. Certificate No 06/4325 is accordingly awarded to Durgo Verkstads AB.

On behalf of the British Board of Agrément

Date of issue: 31st March 2006

  
Chief Executive